

## Torsion

### Notation:

<p><math>a</math> = name for width dimension</p> <p><math>A</math> = area bounded by the centerline of a thin walled section subjected to torsion</p> <p><math>b</math> = name for height dimension</p> <p><math>c</math> = radial distance to shear stress location</p> <p><math>c_i</math> = inner radial distance to shear stress location</p> <p><math>c_o</math> = outer radial distance to shear stress location</p> <p><math>c_1</math> = coefficient for shear stress for a rectangular bar in torsion</p> <p><math>c_2</math> = coefficient for shear twist for a rectangular bar in torsion</p>	<p><math>G</math> = shear modulus</p> <p><math>J</math> = polar moment of inertia</p> <p><math>L</math> = length</p> <p><math>s</math> = length of a segment of a thin walled section</p> <p><math>t</math> = name for thickness</p> <p><math>T</math> = torque (axial moment)</p> <p><math>\phi</math> = angle of twist</p> <p><math>\pi</math> = pi (3.1415 radians or 180°)</p> <p><math>\rho</math> = radial distance</p> <p><math>\tau</math> = engineering symbol for shearing stress</p> <p><math>\Sigma</math> = summation symbol</p>
---	---

### Deformation in Torsionally Loaded Members

Axi-symmetric cross sections subjected to axial moment or **torque** will remain plane and undistorted.

At a section, internal torque (resisting applied torque) is made up of shear forces parallel to the area and in the direction of the torque. The distribution of the shearing stresses depends on the angle of twist,  $\phi$ . The cross section remains plane and undistorted.

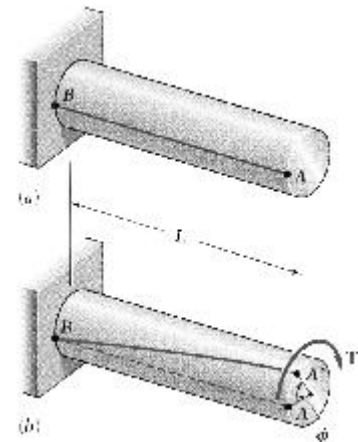
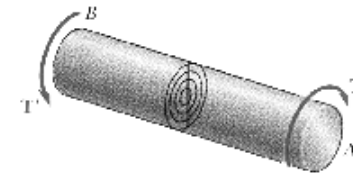

### Shearing Strain

Shearing strain is the angle change of a straight line segment along the axis.

$$\gamma = \frac{\rho\phi}{L}$$

where

$\rho$  is the radial distance from the centroid to the point under strain.

The maximum strain is at the surface, a distance  $c$  from the centroid:  $\gamma_{max} = \frac{c\phi}{L}$

$G$  is the Shear Modulus or Modulus of Rigidity:  $\tau = G \cdot \gamma$

**Shearing Strain and Stress**

In the linear elastic range: the torque is the summation of torsion stresses over the area:

$$T = \frac{\tau J}{\rho} \quad \text{gives:} \quad \tau = \frac{T\rho}{J}$$

Maximum torsional stress,  $\tau_{max}$ , occurs at the **outer diameter** (or **perimeter**).

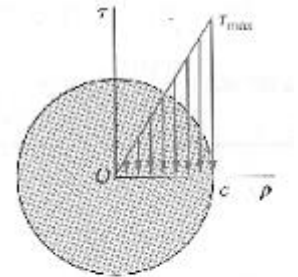

**Polar Moment of Inertia**

For axi-symmetric shapes, there is only one value for polar moment of inertia, J, determined by the radius, c:

solid section:  $J = \frac{\pi c^4}{2}$       hollow section:  $J = \frac{\pi(c_o^4 - c_i^4)}{2}$

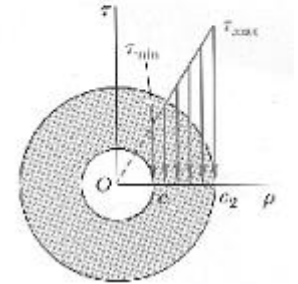

**Combined Torsion and Axial Loading**

Just as with combined axial load and shear, combined torsion and axial loading result in maximum shear stress at a 45° oblique “plane” of twist.



**Shearing Strain**

In the linear elastic range:  $\phi = \frac{TL}{JG}$       and for composite shafts:  $\phi = \sum_i \frac{T_i L_i}{J_i G_i}$

**Torsion in Noncircular Shapes**

J is no longer the same along the lateral axes. Plane sections do not remain plane, but distort.  $\tau_{max}$  is still at the furthest distance away from the centroid. For rectangular shapes:

$$\tau_{max} = \frac{T}{c_1 a b^2} \quad \phi = \frac{TL}{c_2 a b^3 G}$$

For  $a/b > 5$ :

$$c_1 = c_2 = \frac{1}{3} \left( 1 - 0.630 \frac{b}{a} \right)$$

TABLE 3.1. Coefficients for Rectangular Bars in Torsion

a/b	c <sub>1</sub>	c <sub>2</sub>
1.0	0.208	0.1406
1.2	0.219	0.1661
1.5	0.231	0.1958
2.0	0.246	0.229
2.5	0.258	0.249
3.0	0.267	0.263
4.0	0.282	0.281
5.0	0.291	0.291
10.0	0.312	0.312
∞	0.333	0.333

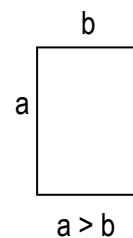
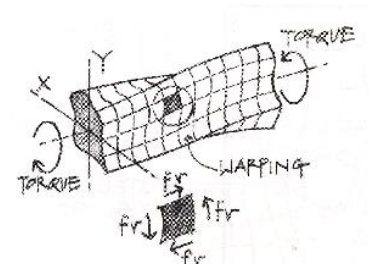

**Open Sections**

For long narrow shapes where  $a/b$  is very large ( $a/b \rightarrow \infty$ )  $c_1 = c_2 = 1/3$  and:

$$\tau_{\max} = \frac{T}{\frac{1}{3}ab^2} \quad \phi = \frac{TL}{\frac{1}{3}ab^3G}$$

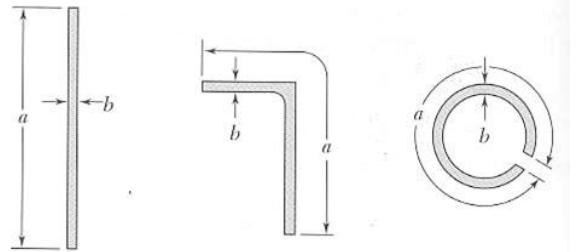

**Shear Flow of Closed Thin Walled Sections**

$q$  is the internal shearing force per unit length, and is constant on a cross section even though the thickness of the wall may vary.  $A$  is the area bounded by the centerline of the wall section;  $s_i$  is a length segment of the wall and  $t_i$  is the corresponding thickness of the length segment.

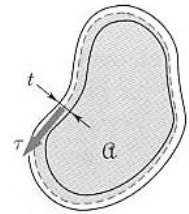

$$\tau = \frac{T}{2tA} \quad \phi = \frac{TL}{4tA^2} \sum_i \frac{s_i}{t_i}$$

**Shear Flow in Open Sections**

The shear flow must wrap around at all edges, and the total torque is distributed among the areas making up the cross section in proportion to the torsional rigidity of each rectangle ( $ab^2/3$ ). The total angle of twist is the sum of the  $\phi$  values from each rectangle.  $t_i$  is the thickness of each rectangle and  $b_i$  is the length of each rectangle.

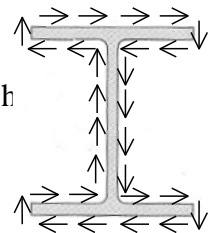

$$\tau_{\max} = \frac{Tt_{\max}}{\frac{1}{3}\sum b_i t_i^3} \quad \phi = \frac{TL}{\frac{1}{3}G\sum b_i t_i^3}$$

Example 1**Example 8.9.1**

Compare the torsional resisting moment  $T$  and the torsional constant  $J$  for the sections of Fig. 8.9.4 all having about the same cross-sectional area. The maximum shear stress  $\tau$  is 14 ksi.

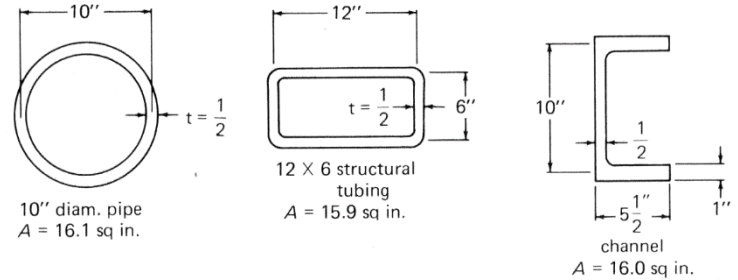
**SOLUTION**

(a) Circular thin-wall section.

$$T = \frac{\tau J}{\rho} = \frac{(14 \text{ ksi})(393.7 \text{ in}^4)}{5.25 \text{ in}} \cdot \frac{1 \text{ ft}}{12 \text{ in}} = 87.5 \text{ k-ft}$$

$$J = \frac{\pi(c_o^4 - c_i^4)}{2} = \frac{\pi((5.25 \text{ in})^4 - (4.75 \text{ in})^4)}{2} = 393.7 \text{ in}^4$$

(b) Rectangular box section.  $\tau = \frac{T}{2t\bar{A}}$

$$T = \tau 2t\bar{A} = (14 \text{ ksi})2(0.5 \text{ in})(72 \text{ in}^2) \cdot \frac{1 \text{ ft}}{12 \text{ in}} = 84 \text{ k-ft}$$

$$\bar{A} \approx (12 \text{ in})(6 \text{ in}) = 72 \text{ in}^2$$

(c) Channel section. Since for this open section,

$$\tau_{max} = \frac{T t_{max}}{\frac{1}{3} \sum b_i t_i^3} = \frac{T t}{J} \quad T = \frac{\tau J}{t_{max}} = \frac{(14 \text{ ksi})(4.08 \text{ in}^4)}{1 \text{ in}} \cdot \frac{1 \text{ ft}}{12 \text{ in}} = 4.8 \text{ k-ft}$$

the maximum shear stress will be in the flange. Also,

$$J = \sum \frac{b t^3}{3} \quad J = \frac{1}{3} [10 \text{ in}(0.5 \text{ in})^3 + (5.5 \text{ in})(1 \text{ in})^3 + (5.5 \text{ in})(1 \text{ in})^3] = 4.08 \text{ in}^4$$