

other beams & pinned frames



Continental train platform, Grimshaw 1993

Pinned Frames

- structures with at least one 3 force body
- connected with pins
- reactions are equal and opposite
 - non-rigid
 - rigid

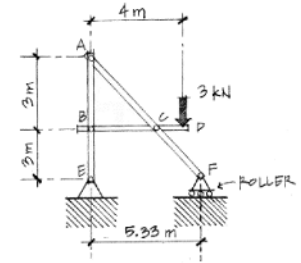
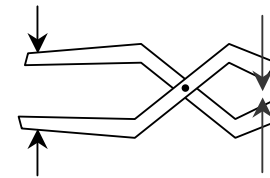

Pinned Frames 2
Lecture 10

Foundations Structures
ARCH 331

F2008abn

Pinned Frames 1
Lecture 9

Architectural Structures
ARCH 331

F2009abn

Rigid Frames

- rigid frames have no pins
- frame is all one body
- typically statically indeterminate
- types
 - portal
 - gable

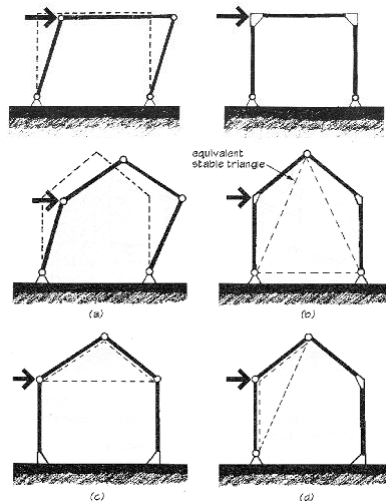

Pinned Frames 3
Lecture 10

Foundations Structures
ARCH 331

F2008abn

Rigid Frames with PINS

- frame pieces with connecting pins
- not necessarily symmetrical

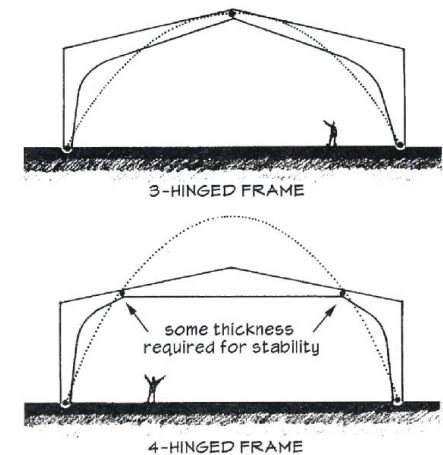

Pinned Frames 4
Lecture 10

Foundations Structures
ARCH 331

F2008abn

Internal Pin Connections

- *statically determinant*
 - 3 equations per body
 - 2 reactions per pin + support forces

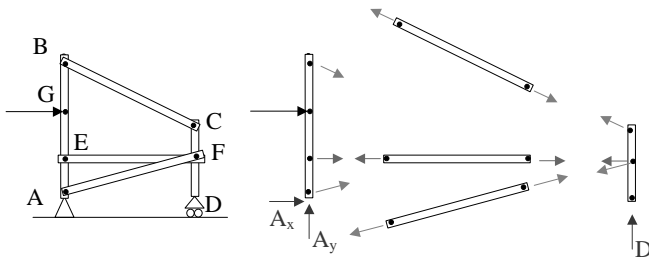

Pinned Frames 5
Lecture 10

Foundations Structures
ARCH 331

F2008abn

Arches

- *ancient*
- *traditional shape to span long distances*



Rainbow Bridge National Monument

Pinned Frames 6
Lecture 10

Foundations Structures
ARCH 331

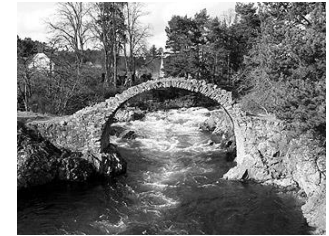

Packhorse Bridge, UK



Roman Aqueducts

F2008abn

Arches

- *primarily sees compression*
- *a brick "likes an arch"*

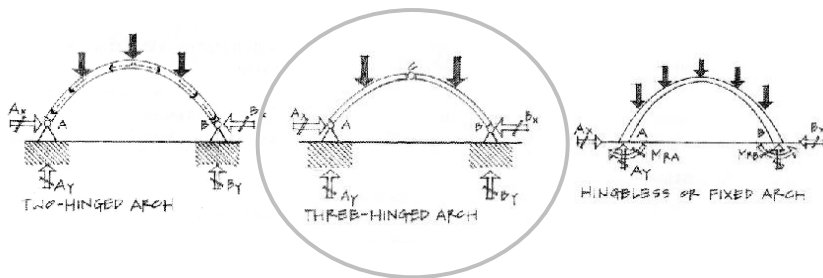

Pinned Frames 7
Lecture 10

Foundations Structures
ARCH 331

F2008abn

Arches

- *behavior*
 - *thrust related to height to width*

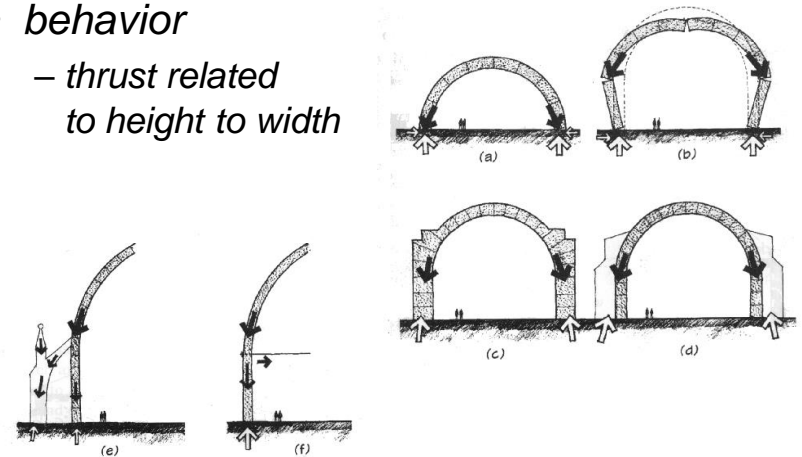

Pinned Frames 8
Lecture 10

Foundations Structures
ARCH 331

F2008abn

Three-Hinged Arch

- *statically determinant*
 - 2 bodies, 6 equilibrium equations
 - 4 support, 2 pin reactions (= 6)

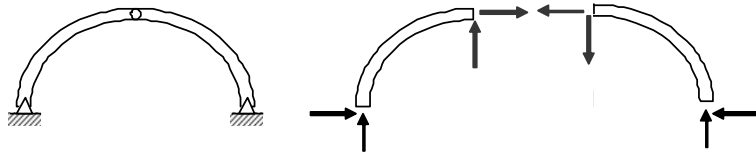

Pinned Frames 9
Lecture 10

Foundations Structures
ARCH 331

F2008abn

Compound Beams

- *statically determinant when*
 - 3 equilibrium equations per link =>
 - total of support & pin reactions (properly constrained)
- *zero moment at pins*

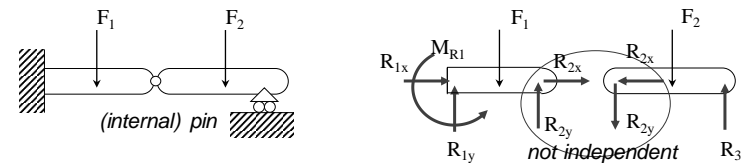

Pinned Frames 10
Lecture 10

Foundations Structures
ARCH 331

F2008abn

Procedure

- *solve for all support forces you can*
- *draw a FBD of each member*
 - pins are integral with member
 - pins with loads should belong to 3+ force bodies
 - pin forces are equal and opposite on connecting bodies
 - identify 2 force bodies vs. 3+ force bodies
 - use all equilibrium equations

Pinned Frames 11
Lecture 10

Foundations Structures
ARCH 331

F2008abn

Rigid Body Types

- *two force bodies*
 - forces in line, equal and opposite
- *three force bodies*
 - concurrent or parallel forces

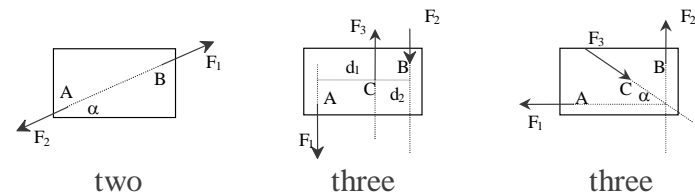

Pinned Frames 12
Lecture 10

Foundations Structures
ARCH 331

F2008abn

Continuous Beams

- statically indeterminate
- reduced moments than simple beam

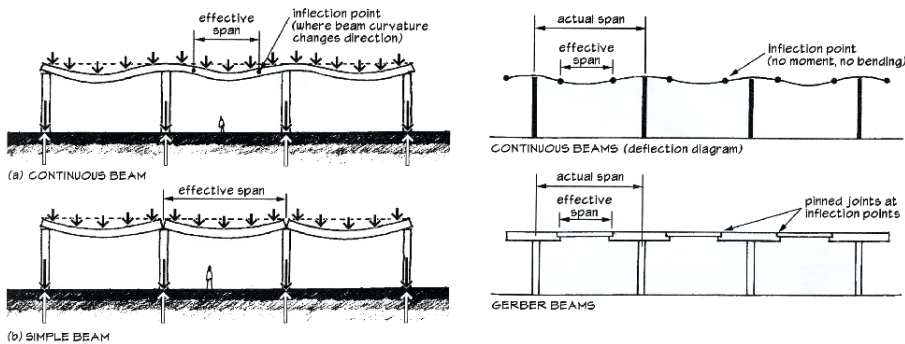

Pinned Frames 13
Lecture 10

Foundations Structures
ARCH 331

F2008abn

Continuous Beams

- loading pattern affects – moments & deflection

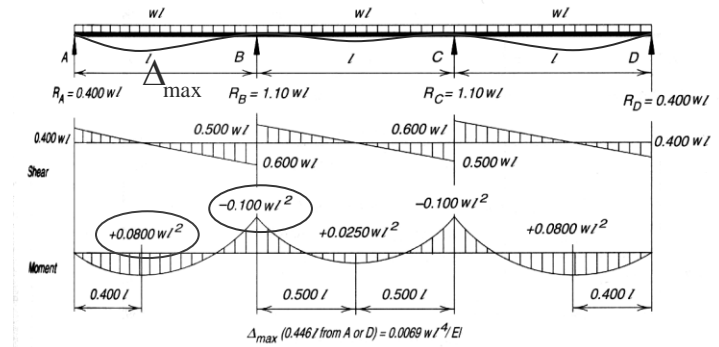

Pinned Frames 14
Lecture 10

Foundations Structures
ARCH 331

F2008abn

Continuous Beams

- unload end span

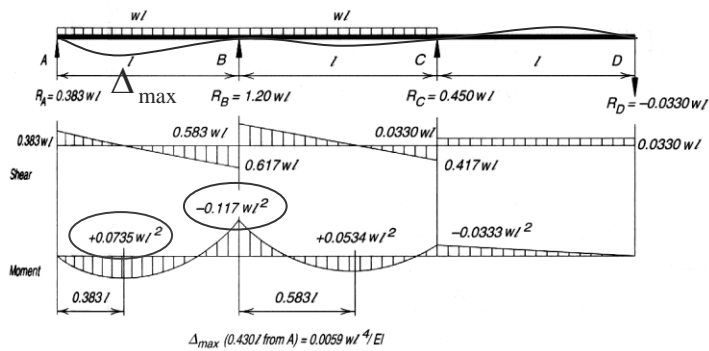

Pinned Frames 15
Lecture 10

Foundations Structures
ARCH 331

F2008abn

Continuous Beams

- unload middle span

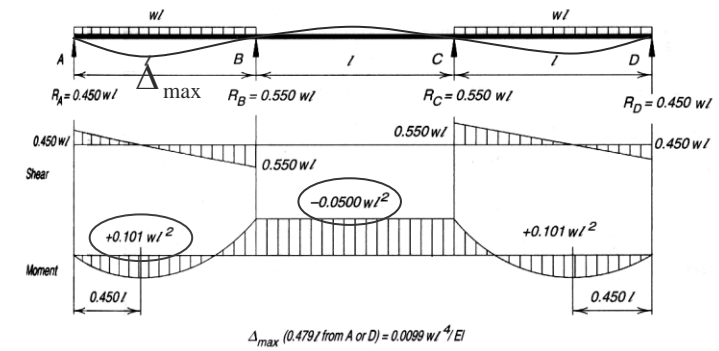

Pinned Frames 16
Lecture 10

Foundations Structures
ARCH 331

F2008abn

Analysis Methods

- **Approximate Methods**
 - location of inflection points
- **Force Method**
 - forces are unknowns
- **Displacement Method**
 - displacements are unknowns

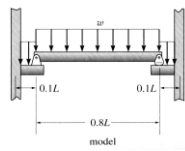
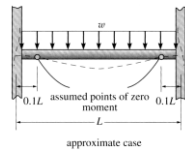

Pinned Frames 17
Lecture 10

Foundations Structures
ARCH 331

F2008abn

Two Span Beams & Charts

- equal spans & symmetrical loading
- middle support as flat slope

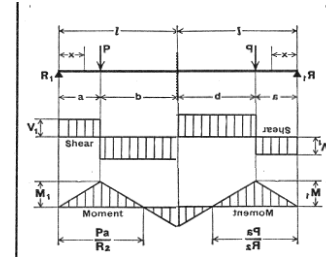

Pinned Frames 18
Lecture 10

14. BEAM FIXED AT ONE END, SUPPORTED AT OTHER—
CONCENTRATED LOAD AT ANY POINT

$R_1 = V_1$	$= \frac{Pb^3}{2l^3}(a+2l)$
$R_2 = V_2$	$= \frac{Pa}{2l^3}(3l^2 - a^2)$
M_1 (at point of load)	$= R_1 a$
M_2 (at fixed end)	$= \frac{Pab}{2l^2}(a+l)$
M_x (when $x < a$)	$= R_1 x$
M_x (when $x > a$)	$= R_1 x - P(x-a)$
Δ_{max} (when $a < .414l$ at $x = \frac{l^2+a^2}{3l^2-a^2}$)	$= \frac{Pa}{6EI} \sqrt{\frac{a}{3l^2-a^2}}$
Δ_{max} (when $a > .414l$ at $x = l\sqrt{\frac{a}{2l+a}}$)	$= \frac{Pab^3}{6EI} \sqrt{\frac{a}{2l+a}}$
Δa (at point of load)	$= \frac{Pa^2b^3}{12EI l^3}(3l+a)$
Δx (when $x < a$)	$= \frac{Pb^3x}{12EI l^3}(3a/l^2 - 2/x^2 - ax^2)$
Δx (when $x > a$)	$= \frac{Pa}{12EI l^3} (l-x)^2 (3l^2x - a^2x - 2a^3)$

Foundations Structures
ARCH 331

F2008abn